



Step Thru

Fast, Flexible Access

in all terrains for a more
Profitable, Safer Workplace



Mobile Access



Fast Relocation



Indoor Outdoor



Australian Made

Fast, Flexible Access
in all terrains for a more Profitable, Safer Workplace

Step-Thru

StockMaster Step-Thru is an all terrain, safe and easy to use Mobile Step-Way Ladder

With two large diameter wheels Step-Thru moves easily over sealed or unsealed surfaces and slopes making it ideal for indoor or outdoor use. Featuring just one control it is fast and easy to move around. Taking hold of the control raises the unit to the mobile position and provides positive easy steering to move to the job. Release of the control automatically returns Step-Thru to the stationary mode where it is braked and totally stable.

A stable step of platform creates a much safer product

The dangerous practice of climbing onto and jumping down from trucks, or the use of step ladders to access containers, mezzanine floors and similar situations is eliminated, significantly reducing the risk of accident. With a stable stepping off platform and two side safety rails to maintain a firm hand hold, access to the work place is safe and easy.

Step-Thru substantially reduces your exposure to the high cost of lost time injuries and compensation claims.

StockMaster Step-Thru is manufactured from high quality materials and built to last. With reasonable care it will provide many years of service, and continue to provide safe access to the workplace.

StockMaster Step-Thru Mobile Step-Ways . . .

- ✓ Provide safe, mobile access
- ✓ Enable a three point contact at all times
- ✓ Move easily over sealed or unsealed surfaces
- ✓ Move quickly and easily to where you need them
- ✓ Are designed and tested to a 150 kg load rating
- ✓ Meet Australian, New Zealand, US and European Union Standards
- ✓ and, with 10 available sizes there is one to suit your job.



Step-Thru moves easily over sealed or unsealed surfaces making it ideal for indoor or outdoor use.



Featuring just one control for braking and steering it is fast and easy to move around.



With two side safety rails to maintain a firm hand hold, access to the work place is safe and easy.

StockMaster Step-Thru meets or exceeds all the requirements of the Australian / New Zealand standard AS/NZS 1892.1:1996, US standard ANSI-ASC A14.2-2007 and the European Standard EN 131: Parts 1 and 2
StockMaster Step-Thru - not just a platform ladder

NOTE: StockMaster Step-Thru is not suitable for use against a wall.
For this application see Mezzalad.

Stockmaster[®] STEP - THRU

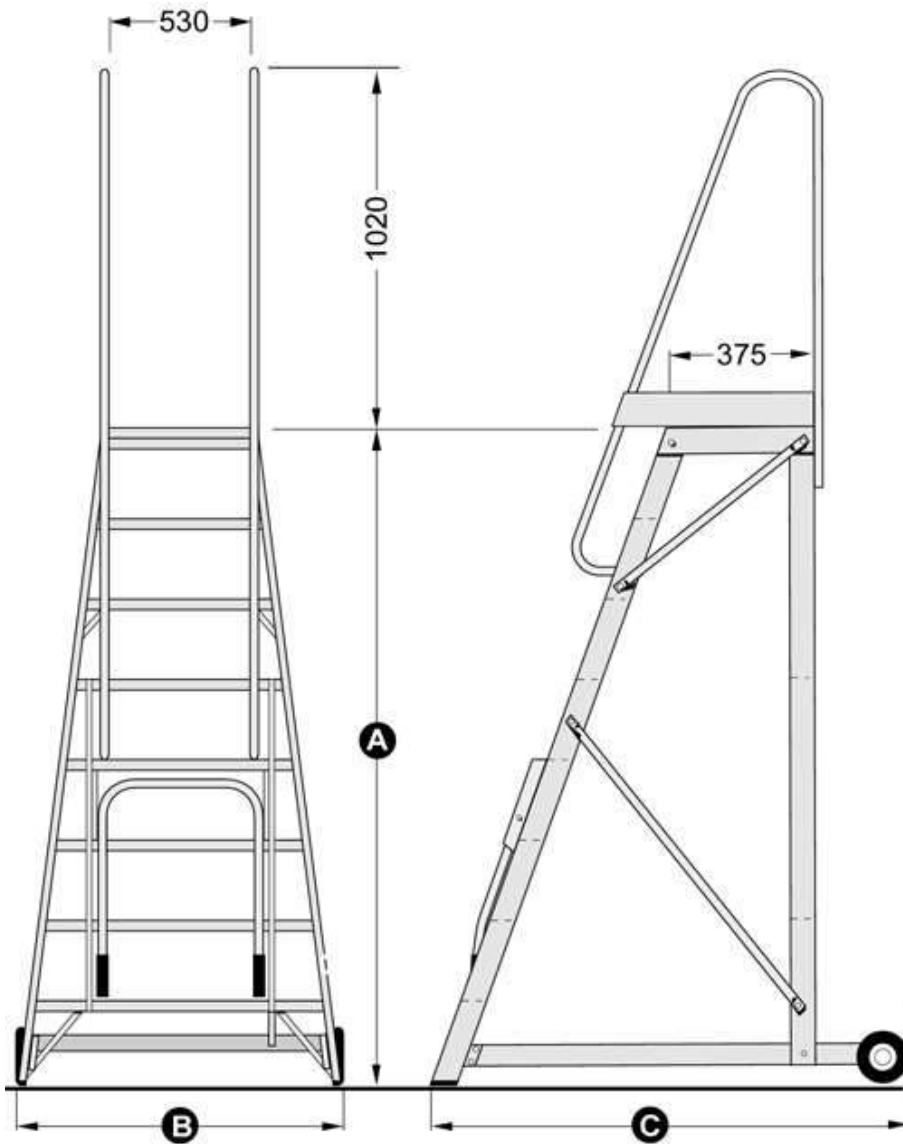

Specifications - January 2009

Model	A	B	C
SM-ST03	860	780	900
SM-ST04	1145	820	1005
SM-ST05	1435	860	1110
SM-ST06	1720	900	1215
SM-ST07	2005	940	1330
SM-ST08	2295	980	1460
SM-ST09	2580	1020	1590
SM-ST10	2865	1060	1720

Note: All Dimensions are in mm.

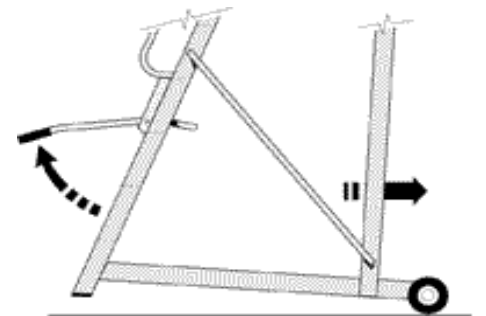

Step - Thru with actuated control handle